



ISO9001、ISO14001、GB/T28001 体系认证企业

ISO9001, ISO14001, GB/T28001 enterprise
management system certification

国家特种设备制造许可证号: TS2710413

State special equipment manufacturing license
number: TS2710413

MDTP61Y-600Class 型

埋地式阀套式排污阀使用说明书

The Operating Manual of MDTP61Y-600Class Type Drain valve of buried pipe valve sleeve type

四川长仪油气集输设备股份有限公司

Sichuan Changyi Oil-gas gathering transportation equipment Co.,Ltd

地址: 中国·四川乐山市高新区南新路1089号

Add: Nanxin Road No.1089, High Tech Zone,Leshan,Sichuan,China

电话 Tel: +86 833-2032315 2030238

传真 Fax: +86 833-2032316 邮编 Zip Code: 614000

邮箱 E-mail: lscy@vip.163.com

网址 Website: <http://www.cyvalve.com>

1. 概述 Overview

MDTP61Y 埋地焊接式阀套式排污阀是我公司在原阀套式排污阀的基础上经过二次改进开发，推出的新型结构排污阀门。阀套式排污阀采用节流轴与阀座喷嘴、套垫窗口与阀座通道、阀芯底端与阀套窗口、节流面与密封面完全分开等多项先进技术，完全打破了传统的排污阀结构功能原理。具有密封零泄漏、耐冲刷、防堵塞、密封面自清扫、自动排渣、节流降压、满足微粒杂质排放等优良性能，特别能适应恶劣工况条件下的排污要求，使用寿命比传统排污阀高 8-10 倍。投放市场多年以来，取得了良好的使用业绩。经国内油气工程专家鉴定，技术水平国际先进，填补了阀类空白，2004 年评为国家重点新产品。可广泛用于石油、天然气、化工、冶金等行业管道集输装置直接排污。

MDTP61Y buried welded valve type drain valve is set in the company the original valve sleeve type drain valve pass by to improve secondary development, on the basis of the launch of the new structure of drain valve. Valve with throttle shaft sleeve type drain valve and valve seat nozzle, cushion cover, window on the bottom of the channel with the valve seat, valve core and valve set is completely separated from the window, the throttling face and sealing surface such as a number of advanced technology, completely broke the traditional drain valve structure function principle. With zero leakage sealing, scouring resistance, anti clogging, sealing surface cleaning, self-discharging, throttling depressurization, meet other excellent properties of particulate emissions of impurities, especially under the condition of can adapt to bad working condition requires that the service life of the 8 to 10 times higher than traditional drain valve. Put on the market for many years, and achieved good results. By domestic oil and gas engineering expert testimony, the international advanced technical level, to fill the gaps valve type, rated as national key new products in 2004. Can be widely used in petroleum, natural gas, chemical industry, metallurgy and other industries gathering pipe plant sewage directly.

2. 性能规格 Performance Specifications

2.1 适用介质：油品、天然气、及各种腐蚀性气液介质。

It applicated for media: oil, natural gas, and all kinds of corrosive liquid medium.

2.2 压力等级 Pressure Level: 600Class (10.0MPa)

2.3 公称通径DN Nominal diameter: NPS6"~16" (DN150~DN 400)

2.4 使用温度范围 Use temperature range: -46℃~130℃.

2.5 产品技术规范 Product technical specifications:

API 6D、ASME B31.8、GB/T12235、GB/T12224

2.6 结构长度标准 The standard of the structure and the length:

ANSI B16.10、GB/T12221

2.7 试验与检验标准 Test and inspection standards:

API 598、GB/T13927、JB/T9092

2.8 阀门埋地部分（阀体及加长杆套筒等）防腐及绝缘处理，按 SY/T 0447 《埋地钢质管道环氧煤沥青防腐层技术标准》。

Valves buried part (body and increase pole sleeve, etc.) to processe with anti-corrosion and insulation, according to SY / T 0447"Buried steel pipeline Epoxy coal tar anticorrosion level technology standards."

3. 结构型号及安装尺寸 Structural models and installation size

3.1 型号说明 Model explanation

型号说明 Model explanation	MDTP6 1 Y — 600Class
MD	表示埋地式 Buried type
TP	表示阀套式排污阀 Valve type drain valve
6	表示焊接式 Welded
1	表示结构形式为直通 Direct connection structure
Y	表示硬质合金密封副 Hard alloy seal
600Class	表示压力等级 Pressure Level

3.2 安装外形尺寸和结构详见图 1

Installation dimensions and structural details, see Figure 1



图 1、阀门安装外形尺寸和结构图

Figure 1, valves installed outside dimensions and structural plans

3.3 各阀门安装外形具体尺寸见表 1

The valve installation specific outline dimensions are shown in table 1

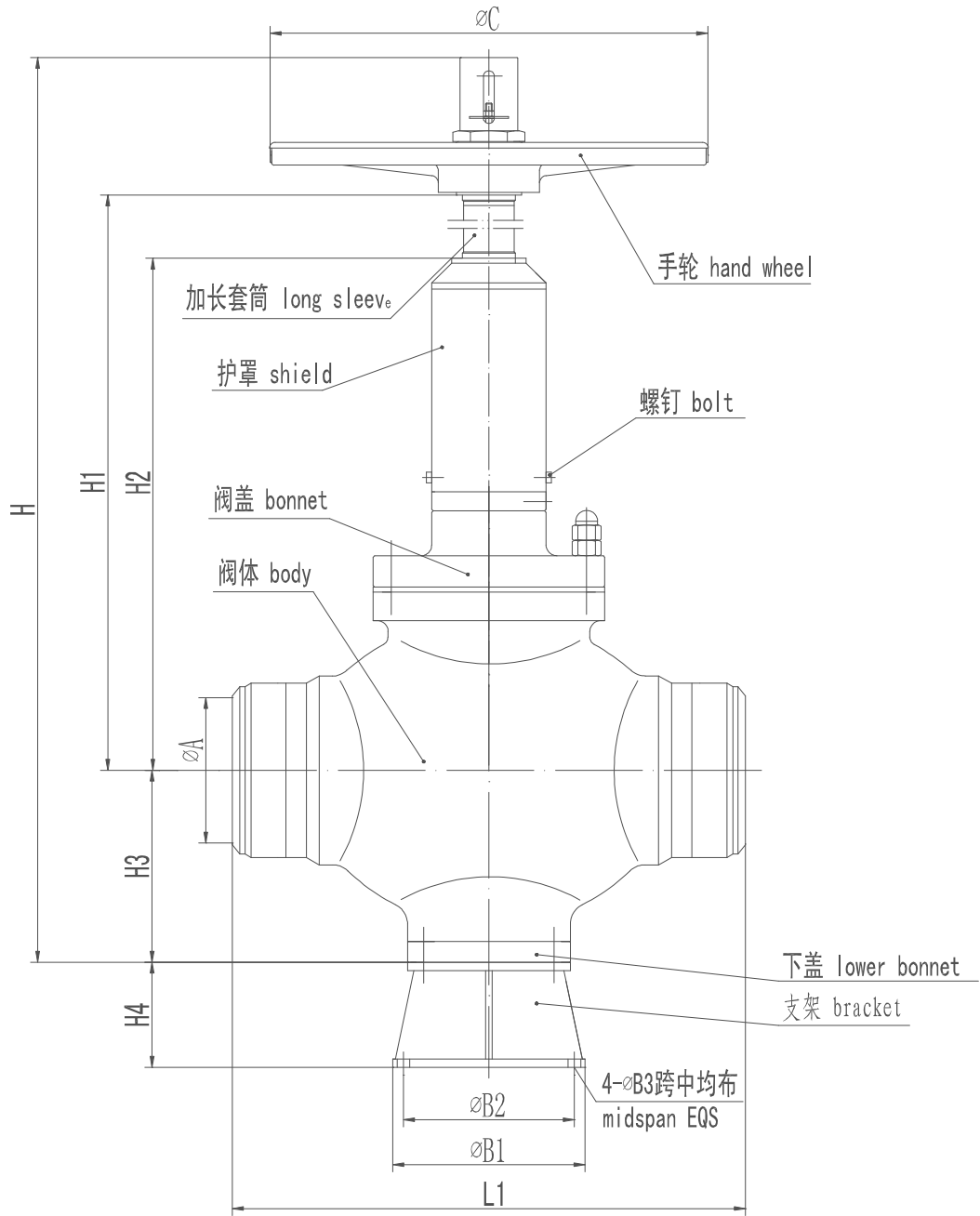
表 1 阀门安装外形具体尺寸
table 1 The valve installation specific outline dimensions

型号 TYPE	MDTP61Y-600class 6"	MDTPFJ61Y-600class 12"	MDTPFJ61Y-600class 16"
L1	830	1380	1700
H	2904	3122	3248
H1	2500	2500	2500
H2	1700	1680	1750
H3	215	366	453
H4	150	150	200
A	150	290	380
B1	250	360	400
B2	210	310	350
B3	20	24	24
C	550	750	800

说明：1、表中各数值尺寸单位为 mm。
2、接管尺寸 ϕA 和定货单位的接管尺寸相配。

NOTE: 1、In the table 1, the numerical size of the unit is mm.
2、The size of the takeover of ϕA and order the unit over suitable size.

4. 工作原理 Working Principle

4.1 关闭状态：嵌在阀芯内腔的聚四氟乙烯端面紧压在阀座端面形成一道软密封；阀芯硬密封副内腔锥面压在阀座凸台锥面上形成第二道硬质密封。在软密封弹性变形的同时，硬软双质密封保证气体介质“零泄漏”。

4.1 Close action

Inner cavity cone of hard seal of valve plug is tightly compressed on raised cone of valve seat to form hard seal; in addition, fluoro-plastic side of plug inner cavity is tightly compressed valve seat side to form second seal. Such double hard and soft seal systems ensure “zero leakage” of medium.

4.2 节流排污状态：阀芯硬软双质密封副离开阀座一段行程后，即阀芯密封面与阀座密封面有一定空间距离时，阀门缓慢开启，管道中的介质、杂质一同经过节流轴、套垫窗口、阀套窗口节流后，由阀套排污窗口排污。嵌在阀芯内腔的软密封面利用进口介质流道方向与介质流道出口方向改变产生的涡流，实现自清扫，使软密封面不粘附杂质。

4.2 Throttling and blowdown action

Following separation of plug hard seal from soft seal, i.e. forming certain space between plug seal surface and valve seat seal surface, valve will be

slowly opened, and medium with impurity flows through throttle shaft, ports on jacket pad and valve jacket for throttling and then is drained through drainage ports. Soft seal surface in plug inner cavity will be self-cleaned by eddy flow produced by direction change between inlet and outlet of medium, removing impurity on soft seal surface.

4.3 排放关闭状态: 管道中介质排放后阀门关闭, 节流轴和阀座喷嘴配合运行一段距离后, 管道中的介质只有小于配合间隙的杂质才能流到阀座密封面处, 此时套垫台阶斜角处才开始进入阀座通道, 使流阻系数进一步增加, 介质流速加快, 套垫台阶斜角利用改变介质流动方向产生的介质径向力, 实现阀座密封面的吹扫。阀芯密封副接近阀座时, 通过配合间隙过来的微粒杂质, 在阀芯凹面内涡流旋转力和阀座介质径向力的吹扫作用下, 阀门密封副完全清扫干净, 保证了阀门排污后的密封性能。

4.3 Drainage close action

After medium in piping drained, valve is closed. Following throttle shaft with valve seat nozzle runs through a section of distance impurity in piping medium only smaller than fit gas can flow into valve seat surface. At this moment, jacket pad oblique angle starts to enter valve seat path, drag coefficient is increased, medium speed is quickened, medium reduction is changed at oblique angle, medium radial force on valve seat side is increased, so valve seat seal surface is purged. Following close of valve plug seal to valve seat, flow rate quickening, increment of eddy rotation force and purge of medium cross force impurity on seal through fit gas will be fully removed, to ensure seal performance of valve after drainage.

5. 性能特点 Performance and Features

5.1 密封可靠: 阀芯、阀座采用硬软双质密封副, 满足高压气、液介质“零泄漏”。

Reliable Seal: The spool and the seat have hard and soft seals, which can meet the requirement of high-pressure gas and liquid media “zero leakage”.

5.2 节流功能: 采用节流轴与阀座喷嘴、套垫窗口与阀座通道、阀芯底端与阀套窗口的多级节流结构设计, 既能满足排污流量的变化, 又能满足不同工况的需要, 而且有效缓减了含湿气和沙粒较重的介质对阀芯密封副的冲刷。

Throttling features: adopts throttling nozzle with the valve seat, and seat cushion cover window channel, the bottom of the valve core and valve sleeve window of multistage throttle structure design, can meet the discharge

flow of change, and to meet the needs of different working conditions, and effectively ease the medium containing sand moisture and heavier to scour the sealing pair of valve core.

5.3 缓压空行程: 在节流轴和阀座喷嘴、套垫与阀座内腔、阀芯与阀套下端配合处分别设有一段等距同步缓压空行程,使得阀芯离开阀座密封面有足够空间距离时,介质才开始节流、排放,降低了密封面受到的冲刷力,有效保护密封面。

Slow pressure air travel: in the throttle shaft and seat nozzle, cushion cover inner cavity with the valve seat, valve core and valve sleeve bottom has a fit place isometric synchronous slow pressure air travel, leave the seat sealing surface makes the valve core has enough space distance, the media began to choke, emissions, reduce the sealing surface erosion force, effectively protect the sealing surface.

5.4 自清扫功能: 阀门关闭过程中,套垫与阀座通道的配合间隙阻止较大颗粒介质流向密封付,介质从套垫斜角处进入阀座通道,流阻系数增加,流速加快,阀座端面介质径向力增加,实现阀座密封面的吹扫;阀芯底部凹槽处由于介质改变流向产生涡流,实现软密封副的自吹扫,从而避免了硬软密封面粘附杂质,保证了阀门排污后的密封性能。

Self cleaning function: in the process of valve closing, cushion cover and seat channels to cooperate to prevent the flow direction of medium particle seal larger pay gap, dielectric from the set of access to the seat pad Angle, flow resistance coefficient increases, the velocity is accelerated, the seat facing medium radial force increase, realize the purging of valve seat sealing surface; Groove at the bottom of the valve core place due to the change of medium flow to produce eddy current, realizes the soft seal since the purging, thereby avoiding the hard and soft sealing surface adhesion impurities, guarantee the sealing performance of valve after discharge.

5.5 排污功能: 排放时,阀门内部设置的缓压空行程,避开了开启时高压差介质的直接冲刷,能有效保护密封面,延长阀门使用寿命。阀门关闭过程中,硬、软双质密封面的自清扫,避免了硬、软双质密封面粘附杂质,防止了关闭后密封面被划伤,保证密封可靠,满足恶劣工况条件下排污使用要求。

Drainage function: when emissions, slow pressure of valve set inside the empty travel, away from the opening pressure difference directly flushing medium, can effectively protect the sealing surface, extend valve life. Valve closed in the process, hard and soft double sealing surface of the cleaning,

avoid the hard and soft double sealing surface adhesion of impurities, prevents the sealing surface scratches after closing, ensure reliable sealing, satisfies the requirement of sewage using harsh operating conditions.

5.6 自动除渣: 阀芯设有两道 O 形圈, 且在两道 O 形圈间设有贮渣槽, 贮渣槽下端 O 形圈使阀芯在阀套内上下移动实现自动除渣。

Auto Cleaner: Spool has two O-rings with a storage tank for residue and the O-ring at the bottom of the storage tank makes the spool to move up and down in the bolt-sleeve so as to automatically clean the residue.

5.7 阀芯开设平衡孔和贮渣槽, 启闭力矩小, 开启轻便灵活。

Spool with balance hole and slag storage slot, hoist torque small, open flexible and light.

5.8 阀杆填料函密封填料间设置了 O 形密封圈与聚四氟乙烯填料交叉作用, 保证阀杆处不泄漏和延长阀杆使用寿命。

Packed in a sealed set up between the O-ring PTFE packing and cross-role, we do not guarantee that stem leakage and extend the life of stem.

6. 主要零部件材料表 The main components of materials table

零件名称 Part name	材料 Material
阀体、阀盖 Valve body and Bonnet	ASTM A352/LCB、LCC; ASTM A216/WCB、WCC
阀芯、阀座 Needle base	2Cr13 密封面堆焊 Stellite 合金 2Cr13 trim overlay welding Stellite alloy
阀杆 Stem	2Cr13
密封垫 sealing gasket	聚四氟乙烯 PTFE
填料 Padding	聚四氟乙烯 PTFE
阀杆螺母 Stem nut	铜合金 Aldary
手轮 Handwheel	20 Steel
护罩 Shields	Q235-A
加长套筒 Long sleeve	20 Steel
焊接圈 Welding ring	ASTM A350/LF2
螺栓 bolt	ASTM A193 B7/35CrMoA
螺母 nut	ASTM A194 2H/35、30CrMo
其余内件 The rest of the internal parts	不锈钢 Stainless steel

7. 排污阀安装、调试和维护保养 Drain Valve installation, commissioning

and maintenance

7.1 安装操作要求 The installation of operating requirements

7.1.1 排污阀为常闭阀门，使用于管线排污及其他常闭工作条件。

Drain valve is closed valves, used in Line drainage and other closed working conditions.

7.1.2 埋地式排污阀可在室内外安装，介质单向流动。阀门安装时应注意阀体上的介质流动方向，阀体上的介质流动箭头标识应与管道介质流动方向一致。

Buried type drain valve can be installed indoor and outdoor, media flows in one direction. When installing the valve should pay attention to the flow direction of medium on the valve body, medium flow arrow logo on the valve should be consistent with flow direction of pipeline medium.

7.1.3 安装位置应保证维修、检查、操作有足够的空间。

The Installation location should ensure the enough room for maintenance, inspection, and operation.

7.1.4 安装时注意保护阀门连接部位表面不要碰伤、划伤，确保连接密封可靠。

Pay attention to protecting the connecting surface parts of the valve flange do not be bumped, scratched and ensure the connection reliable and sealed when installing.

7.1.5 管线清扫和试压时，排污阀应处于关闭状态，防止污物杂质损坏密封面。

When cleaning pipeline and testing pressure, the drain valve should be closed to preventing dirt impurities damaging sealing surface.

7.1.6 试压后用空气扫线排除积水时，应采取其它办法将管道内的较大杂物（如木块、木条、手套、橡胶皮等）事先清除，通过排污阀.杂质、脏物不可太大。

Excluding the water after the air pressure test through scan lines should clean the bigger pipeline debris (such as wood, wood, gloves, rubber, etc.) by other approach at first, impurities and dirt can not be too big by drain valve.

7.1.7 调试阀门时，首先应反时针缓慢转动手轮，使阀门达到最大行程，然后顺时针旋转手轮，使阀门达到最小行程，感觉开启是否轻便灵活，密封是否可靠。

When debugging the valve, firstly should slowly anti-clockwise the switch hands to reach the maximum valve distance, and then clockwise rotate the hand wheel to reach the minimize valve distance, to ensure whether the switch is flexible and the seal is reliable.

7.1.8 我公司排污阀阀芯开设有平衡孔，启闭力矩小，操作轻便灵活。建议现场操作我公司阀门请不要使用加力杆，避免用力过大损坏阀内件。若出现阀门关闭不严的情况，主要是阀芯和阀座密封面粘附有杂质，或软密封被划伤，这时应拆开阀门检查，清理/清洗密封面或更换软密封。

Drain valve of our company has a balanced spool hole, hoist torque is small and operation is lightweight and flexible. We advice not use the afterburner valve rod to avoid excessive force damaging valve pieces when

operating the valve. If the valve is in the case of close lax, mainly because of adhesion impurities on spool and valve seat sealing surface or soft seal was scratched .when in this condition, the valve should be opened to inspect, cleanse or cleaning or replace the soft sealing surface

7.2 使用维护保养 The useing maintenance

7.2.1 阀门未开箱前不要在露天堆放。

Do not stack the valve in the open air before the valve is still in the box.

7.2.2 拆卸检查时，应注意阀体及阀座间的软密封、O 形圈是否损坏，若有则须更换。

Pay attention to the soft seal and the O-ring between the valve body and the seat is damaged or not when demoliting to inspecte, if it is, must be replaced.

7.2.3 阀门在使用中如出现内漏，可旋转手轮连续启闭几次，让介质吹扫阀芯阀座密封面，保证密封面清洁，再投入使用。

In case of leakage when using the valves, can rotate handwheel sluicegate consecutive times and use the media purge spool valve sealing surface to ensure the sealing surface clean, and then put into use.

7.2.4 如吹扫后仍然存在内漏，则切断气源，松开拆卸上盖的紧固螺母，整体将阀芯总成抽出，然后检查阀芯阀座密封面是否有杂质粘附，阀座软密封 O 形圈是否损坏。如有请及时清洁或更换。

If there is still inner leakage after purge, cut off the gas source, loose nut fastening the demolition of the superstructure, pull out the overall assembly spool, and then check whether there is any impurities adhesion on the spool valve sealing surface and wether valves soft block O-ring seal damage,or request cleaning or replacement timely.

8. 排污阀存放条件及维护 Storage conditions and maintenance of the valve

为了不让阀门在保管中损坏或降低质量。对阀门的存放要求作如下说明：

In order not to damage or lower quality of the valve in the custody. Storage requirements of the valve as follows:

8.1 阀门存放维护 Valve storage maintenance

8.1.1 阀门吊运/搬运时不要损坏了包装箱（物），保管应存放于仓库室内，堆码应防潮，存放阀门的仓库要保持清洁干燥。环境相对湿度 $\leq 70\%$ （达不到须增加除湿设备），室内温度保持在 $0-50^{\circ}\text{C}$ 。若临时放置室外的阀门，必须盖上油毡或苫布之类防雨、防尘设施等设施，避免阳光直晒。

Do not damage the packing (material) when lifting or carrying the valve, custody should be kept in storage room, storage warehouse should be moisture-proof to maintain valve clean and dry. Relative humidity $\leq 70\%$ (can not be increased dehumidification equipment), room temperature should be

maintained at 0 to 50 °C. If place valves outdoor provisional, must cover them with linoleum or thatch cloth like rain-proof and dust-proof facilities to avoid direct exposure.

8.1.2 阀门存放保管应井井有条，不能乱堆乱垛，不要堆叠过高，在库房按类别整齐排列，最好用木板与地面隔开，不要让法兰密封面接触地面，以保护阀门不致碰坏。由于保管和搬运不当，手轮损伤，阀杆碰歪，手轮与阀杆的固定螺母松脱丢失等等，这些不必要的损失，应该避免。

The custody of the valve should be kept in good order, do not in chaos or huddle, do not stack too high, arranged neatly by category in the warehouse, it is better to separate it from ground with wooden planks. To preventing the valve not butting bad, do not let flange sealing surface contact with the ground, these unnecessary losses ,for example, the result of improper storage and handling, hand-round injury, stem touch askew, loss or loose nut between hand wheel and stem, should be avoided.

8.1.3 对刚进库的阀门，要进行检查，看是否运输过程中进了雨水、污物或损坏，检查阀门的外表面漆层，并擦试干净，再予存放。每隔半年检查外表面漆层是否脱落，视情况修补。

For the entered valve, it is necessary to check if there is the rain, dirt or damage during the transport process, to check the outer painting surface of the valve and clean, then deposited. Check whether the outer painting surface is off every six months and repair it depending on the circumstances.

8.1.4 阀门入库后，进出口法兰密封面要定期涂敷长效防锈油加以保护，可根据保管条件的实际情况，建议每隔 3 个月或半年涂敷一次；阀门进出口要用防护盖封住，以防脏物进入。

After valve warehousing, in and out flange sealing surface should be protected by coating regular long-acting anti-rust oil ,it is recommended coating every three months or six months according to the conditions under the custody of the actual situation; in and out of the valve should use protective covers sealed to preventing dirt entering.

7.1.5 随机配件软密封 O 型橡胶圈、聚四氟乙烯垫圈等，用塑料袋密封包装后存放于货架（柜），防潮、防尘，并标识清楚。

Random accessories such as soft rubber O-ring seals, PTFE gaskets and should be sealed in plastic bags stored in the shelves after packaging (cabinet), should be moisture-proof, dust-proof and identify clearly.

7.1.6 本阀门的内件材料全部为不锈钢，不受环境气候的影响。

All the materials of the valve are stainless steel, can not be impacted by environmental climate.

8.2 填料检查 The filler check valve stem

检查阀门的密封填料，本阀采用氟橡胶 O 形圈和聚四氟乙烯圈交叠密封。出库前检查一次，必要时可重新装一次。重装压紧填料时，要同时转动阀杆，以

保持四周均匀，并防止太死，拧紧压盖要用力均匀，不可倾斜。

Check valve seal packing, the valve used fluoroelastomers and PTFE O-ring seal overlapping circles. Check out before carrying out of warehouses, it can be reloaded if necessary. When re-fill pressed, it is necessary to rotate the stem at the same time in order to maintain the around uniform and not too much death, tightening screw cap with uniform forcefully pressed, not tilted.

9. 订货须知：订货时请注明以下内容

Ordering Information: When ordering please specify the following

9.1 阀门设计压力、工作压力、公称通径、连接尺寸；

Valve design pressure, the pressure of work DN connecting size;

9.2 使用介质及组成、材质要求；

The use of media and composition of material requirements;

9.3 工作温度； Operating temperature;

9.4 其它特殊要求。 Other special requirements.